

研究ノ一ト **Determination of Precise Positions of the Mainlands
and Isolated Islands in the Japanese Territory †**
—A Review of Marine Geodetic Control Network Deployed
by the Hydrographic Department—

Arata SENGOKU*, Masayuki FUJITA**, Kunio MATSUMOTO*, Koji TERAI***
and Minoru SASAKI****

Abstract

Precise nautical charts have become indispensable both for determination of the outer limit of jurisdictional sea and for the safety at sea. It is because the United Nations Law of the Sea has come into effect in many countries and also because of the advent of GPS that enables navigators to obtain precise position even in the middle of the ocean. Since 1980, the Hydrographic Department of Japan has carried out space geodetic observations, such as satellite laser ranging (SLR) and global positioning system (GPS), to establish geodetic control network in Japanese islands. This paper briefly reviews our activities and several results in space geodesy for precise nautical charts.

1. Introduction

In recent years, higher position accuracy of nautical charts has become required. One major reason is the United Nations Convention on the Law of the Sea. The outer limit of jurisdictional sea has to be drawn in nautical charts according to the Convention. Hence, a high accuracy for the coordinates of baselines has become necessary for the demarcation of the jurisdictional sea. Another reason is the advent of Global Positioning System (GPS). GPS receivers have widely prevailed in the navigation at sea and offer precise position of vessels at any time. Position accuracy of nautical charts has to be improved in order to correspond with high GPS positioning accuracy.

This paper briefly reviews our efforts to

establish precise geodetic control network in Japan using satellite techniques. This was originally presented at the International Hydrographic Conference in 1997 held in Monaco as a morning lecture by Dr. Hideo Nishida.

1.1 Geodetic datums

Tokyo Datum

The former Hydrographic Office in Japan was established in 1871 in Tokyo and an astronomical observatory was installed soon after the establishment in the yard of the Office which was belonged to the Navy at that time. The astronomical observations to establish a geodetic coordinate system for nautical charts were started there. The values of latitude and longitude of the center of a theodolite in the observatory were determined in 1886 by an astronomical method. In 1918, the longitude of

† Received 1998 November 24th ; Accepted 1999 February 1st.

* 航法測地課 Geodesy and Geophysics Division.

** 海洋研究室 Ocean Research Laboratory.

*** 美星水路観測所 Bisei Hydrographic Observatory.

**** 海上保安大学校 Maritime Safety Academy.

the theodolite was astronomically measured again in use of improved time comparison system with the time measured at Greenwich U.K. by means of telegraphy and added 10.4 arc seconds as the result. Since then, the original latitude and the corrected longitude have been used as the values of the origin of the geodetic system in Japan established later and named the Tokyo Datum. Bessel's ellipsoid is used in the Tokyo Datum. The deflection of the vertical (Figure 1) at the origin is assumed to be zero. The Tokyo Datum is one of non-geocentric geodetic datums and the reference ellipsoid fits the earth's surface only around Japan.

It is known today that the Tokyo Datum deviates from the worldwide geodetic systems primarily owing to the deflection of the vertical in Tokyo. Namely, the mountains in the central part of Japan at northwestern area from Tokyo and a trench in the Pacific Ocean at the southeastern area from Tokyo cause the inclination of the plumb line due to non-uniform mass distribution. Therefore, the Tokyo Datum has to be connected to the worldwide geodetic systems by satellite techniques.

The worldwide geodetic systems

The definition of the worldwide geodetic systems is as follows,

- 1) the origin is the geocenter,
- 2) z-axis is along the spin axis of the earth,

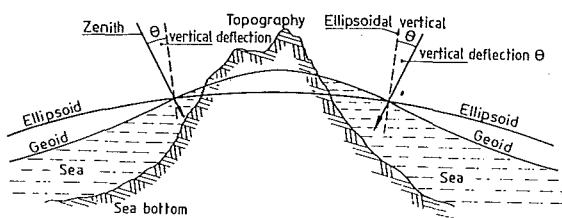

Figure 1. The deflection of the vertical (after Seeber, 1993).

- 3) and x-axis is within the Greenwich meridian plane.

The worldwide geodetic systems have been realized by space geodetic observations which are described later. ITRF is the most clearly defined worldwide geodetic system published every year by International Earth Rotation Service (IERS). ITRF is a combined solution of several space geodetic analysis results. WGS-84 is the most prevalent worldwide geodetic system defined by the Department of Defense of the U.S. though it was changed several times without notice. There are several other worldwide geodetic systems. The typical difference among these systems is less than a meter.

1.2 Space geodetic activities at the JHD

The Hydrographic Department of Japan (JHD) has taken part in space geodesy since the early stage of the artificial satellite history.

In the 1960's, the JHD carried out satellite geodesy making use of the satellites Echo I, II and the geodetic satellite Pageos and determined the positions of several off-lying islands around Japan. However, as the observation was made only by photographic method, the accuracy was estimated to be a few tens of meters. In the 1970's, a new technique for position determination of off-lying islands by the use of navigation satellite system, namely, the Navy Navigation Satellite System (NNSS) was introduced. The positions of many islands were determined by the so-called Doppler observations of NNSS satellites with point positioning strategy at this period whose accuracy of positioning is estimated to be a few tens of meters. Although the accuracy in both photographic observation of satellites and the point positioning NNSS observation were quite insufficient from the present point of view, the results contributed greatly to correct the posi-

tions of many off-lying islands which had been determined astronomically in the previous years. The correction of the island position amounted to more than a kilometer in some cases. The results have been reflected on the nautical charts published by the JHD, i.e., in the newly published or revised charts the positions of the off-lying islands have been corrected based on the results of the satellite observations for those islands.

As is previously described, a higher position accuracy of off-lying islands has come to be required recently, and a quite new full scale geodetic work, called marine geodetic control network, was commenced by the JHD by applying the space geodetic methods of Satellite Laser Ranging (SLR), GPS and NNSS. Also a Japanese geodetic satellite Ajisai was launched for supporting our work.

2. SLR

2.1 What is SLR ?

SLR is a technique which measures the round trip time of an optical laser pulse between a ground-based station to a satellite (Figure 2). The laser pulse is directed to the satellite from the station and reflected at the corner cube reflector (CCR) of the satellite back to the

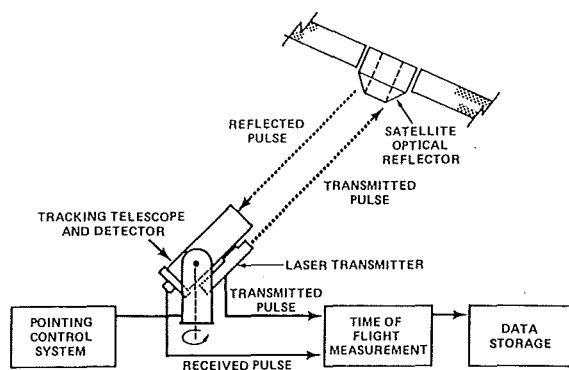

Figure 2. Satellite laser ranging concept (Degnan, 1985).

station. The return pulse is collected by a receiving telescope, is detected by a high-speed photo multiplier, and stops a time interval counter for the measurement of round-trip time.

SLR is the best technique to determine the worldwide geodetic system. SLR uses passive geodetic satellites and is free from political policy of a country, while GPS does depend. Recently, the precision of GPS geodesy has been improved. However, it is well known that the precision of the origin of the worldwide geodetic system determined by SLR is the highest.

2.2 Ajisai satellite

At 5 : 45 a.m. on 13th of August, 1986, JST, the first Japanese geodetic satellite was launched successfully from the Tanegashima Space Center by the National Space Development Agency of Japan (NASDA) as a payload for the first test flight of newly developed H-I rocket. The satellite was named "Ajisai" immediately after the launch.

The launch of this satellite had been requested to the Space Development Committee continuously for more than 15 years by the JHD and the Geographical Survey Institute (GSI), for their own uses. The JHD's intention was to use it for expanding the marine geodetic control network.

The body of Ajisai is a hollow sphere made of glass-fiber-reinforced plastics covered with 1436 CCR's for SLR observation and 318 mirrors (Figure 3). The CCR's are made of fused silica and the mirrors are aluminum alloy with coated surface by silicon oxide. The structure of Ajisai is axially symmetric and it spins rapidly (40 rotations per minute at the orbit insertion). Table 1 gives major specifications of Ajisai (Sasaki and Hashimoto, 1987).

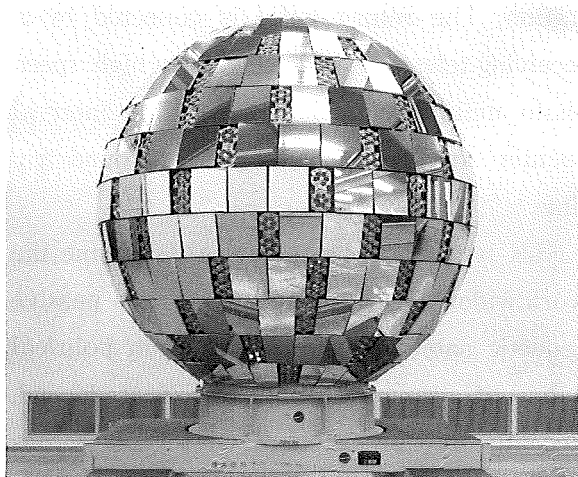

Figure 3. Japanese geodetic satellite, Ajisai. Ajisai is a hollow sphere covered with 1436 corner cube reflectors for SLR and 318 mirrors to reflect sunlight. Its orbit is nearly circular with an inclination of 50 degrees and an altitude of 1500km.

Table 1. Major specifications of Ajisai

total mass	685 kg
total diameter	2.15 m
total effective area for SLR	91.2 cm ²
CCR	1436, 120 sets of CCR arrays
mirror	318
center of mass correction	1.01 m

Ajisai has been used to determine the positions of the principal off-lying islands and the like. The observation and analysis concerning this satellite have played an important role in the marine geodetic control network project. It should be noted that Ajisai has also contributed to Earth sciences such as geopotential recovery and atmospheric density modeling.

3. The marine geodetic control network

For the purpose of the exact demarcation of the boundaries of the jurisdictional sea such as the territorial sea, the exclusive economic zone or the continental shelf area which were provided in the Convention on the Law of the Sea, the project of establishing the marine geodetic

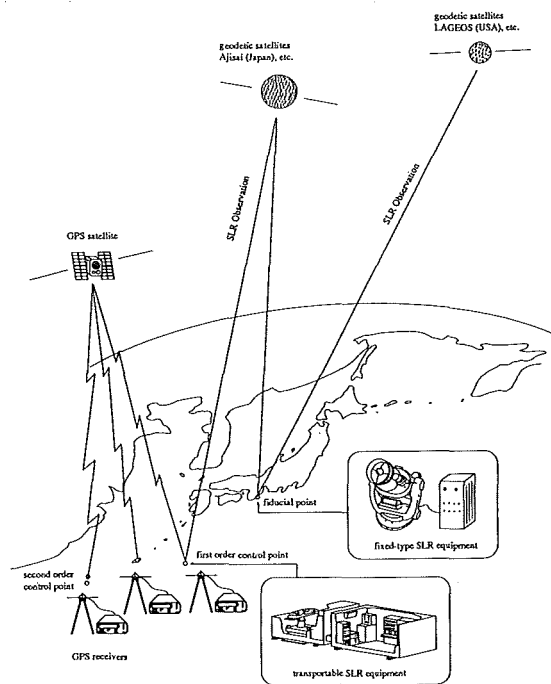

Figure 4. A concept of marine geodesy by using satellite techniques which enable accurate determination of the positions of the mainlands and off-lying islands of Japan. Position of the mainlands is determined by LAGEOS SLR observation at Simosato. Baseline vectors from Simosato to the first order control points are obtained from simultaneous SLR observations at both sites. Positions of the second order control points are measured from the first order control points nearby.

control network was commenced by the JHD in 1980. The project consists of the following three stages (Figure 4) :

- a) The connection of the Tokyo Datum to the worldwide geodetic system : This is carried out by using laser ranging technique and geodetic satellites, such as the U. S. geodetic satellite LAGEOS, at the Simosato Hydrographic Observatory (SHO) where the fiducial point of the marine geodetic control network is established. An SLR system was installed for this purpose at the SHO and the ranging observation has been made since April 1982 (Sasaki et al., 1983).

b) The connection of the principal off-lying islands to the Tokyo Datum : Comparatively large islands which are not connected to the mainlands geodetically at all or connected very poorly are incorporated into the Tokyo Datum by the observation of the Japanese geodetic satellite Ajisai. For this purpose a transportable laser ranging station (HTLRS-1) was completed by the JHD (Sasaki, 1988). The SLR observations of Ajisai are made simultaneously at the SHO and on the islands in use of the HTLRS-1. This observation started in January 1988. The point whose position is determined by the observation of Ajisai is called the first order control point.

c) The connection of the second order control points to the first order ones : On smaller islands are set up the second order control points. The positions of these points are connected to the nearby first order control points by the NNSS observation at first, and GPS later. In this case, the differential method is applied in order to obtain precise relative position. All these observations have been continued since 1980.

Besides, many third order control points are set up near each second order point. Their positions are determined by the conventional survey using a theodolite and a distance meter, not by the satellite technique.

In Figure 5, the location of the control points of each order is shown.

4. Space geodetic observations at the JHD

4.1 SLR observations

Since 1982, the SLR observation of geodetic

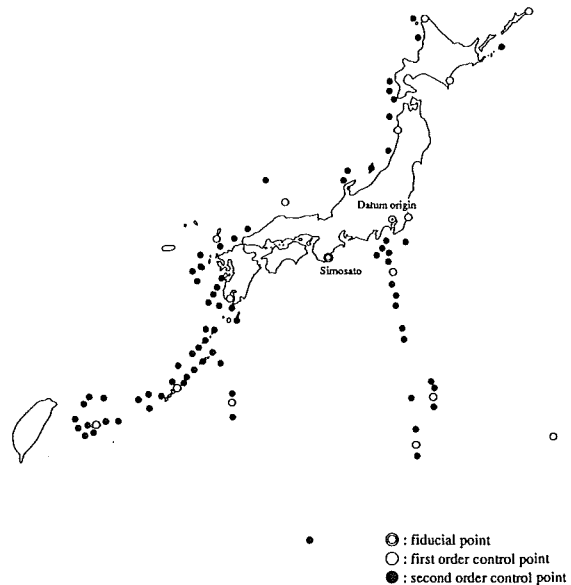

Figure 5. The marine geodetic control network.

satellites has been continued at the SHO for the purpose of determining the relation between the Tokyo Datum and the worldwide geodetic system. The observation data have been reported annually in the Data Report of Hydrographic Observations, Series of Astronomy and Geodesy, and Series of Satellite Geodesy. Table 2 shows yearly statistics of SLR observation at the SHO. Typically, more than one thousand raw range observation data are obtained during a satellite passage, called a pass. Compressed range data, normal points, are sent to NASA and other institutions within 24 hours. Until 1995, eight geodetic satellites have been launched by Japan, the U.S., France, the former U.S.S.R., and Germany. Geodetic satellites are cannon-ball type satellites with CCR's on their surfaces which reflect incident light back to the incident direction.

The work of determining the position of the fiducial point at the SHO in the frame of the worldwide geodetic system requires data exchange of SLR observations to geodetic satellites in cooperation with many other SLR stations distributed all over the world. The

Table 2. Number of observed satellite pass at the Simosato Hydrographic Observatory by the JHDLRS-1, as of the end of 1997

satellite \ year	1982	1983	1984	1985	1986	1987	1988	1989	1990	1991	1992	1993	1994	1995	1996	1997	total
Ajisai					169	277	271	240	215	215	234	203	240	316	250	143	2773
LAGEOS-1	47	137	223	297	224	162	102	93	99	101	100	73	72	125	89	61	2005
LAGEOS-2											15	100	74	126	107	41	463
Starlette	36	116	118	108	92	77	78	63	86	91	84	59	63	146	53	57	1327
ERS-1										28	64	48	45	75	35		295
ERS-2														56	62	50	168
TOPEX/Poseidon											54	67	95	136	69	60	481
Stella												23	61	88	49	32	253
GFZ-1														13	11	3	27
Etalon-1													1	18	0	4	23
Etalon-2													3	34	7	5	49
ADEOS															19	30	49
GPS-36															1	0	1
BE-C	59	199	150	155	56												619
Meteor-3													28	45			73
DIADEME-1C																39	39
DIADEME-1D																20	20
total	142	452	491	560	541	516	451	396	400	435	551	573	682	1178	752	545	8665

National Aeronautics and Space Administration (NASA) of the U.S. has been promoting international projects, such as the Crustal Dynamics Project (CDP), the Dynamics Of the Solid Earth (DOSE), and the Solid Earth and Natural Hazards (SENH) in which many SLR, VLBI and GPS stations have been participating. The NASA has been the data center for the projects which is responsible for collection and dissemination of the space geodetic data. In December 1982, the letters of agreement were exchanged between the JHD and NASA under the control of the Standing Senior Liaison Group (SSLG) for the Japan-U.S. cooperation in non-energy fields. The JHD has other bilateral cooperative relations on the intergovernmental level with Centre D'Etudes et de Recherches Geodynamiques et Astronomiques (CERGA) in France, Institute of Applied Geodesy (IfAG) in Germany, Shanghai Obser-

vatory and Institute of Seismology in China, and Piano Spaziale Nazionale (PSN) in Italy. SLR observation at first order control points started in 1988. The transportable SLR equipment has been transported to first order control points. Typical observation period for a site is 2-4 months. It depends on the climate at the site and the distance between the site and Simosato. Stone markers have been placed at the first order control points. The positions of these points have been connected to the HTLRS-1 by GPS or conventional survey techniques. Table 3 shows pass table obtained at the first order control points.

Instruments

The first SLR system which is of fixed-type, named JHDLRS-1, was installed at the SHO in March 1982, and it has been in operation since then (Figure 6). JHDLRS-1 has been upgraded several times to improve ranging accuracy and

Table 3. Number of observed satellite pass at the first order control points by the HTLRS-1, as of the end of 1997

station	year	Ajisai	LAGEOS-1	LAGEOS-2	Starlette	TOPEX/Poseidon	Stella	ERS-2	total
Titi Sima	1988	38	11		4				53
	1996	35	12	26	3	10	2		88
Isigaki Sima	1988	28	21		2				51
	1997	34	22	2	1	9	4	3	75
Minamitori Sima	1989	45	31						76
Okinawa	1989	48	8						56
Tusima	1989	54	8						62
Oki	1990	32	5						37
Minamidaïto Sima	1990	16	2		2				20
Tokati	1991	34							34
Iwo Sima	1992	37	14		6				57
Wakkanai	1992	32				3			35
Hatizyo Sima	1993	34	4	2		8			48
Makurasaki	1994	21				5			26
Oga	1994	25	2						27
Tyosi	1996	64	8	18	8	4	1		103
total		577	148	48	26	39	7	3	848

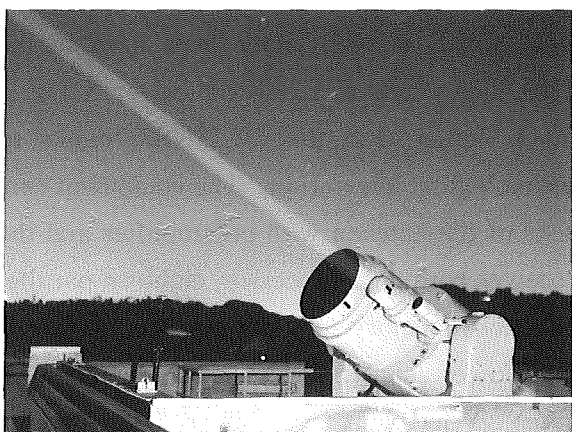

Figure 6. Transmitter and receiver telescopes of the fixed-type satellite laser ranging station, JHDLRS-1, at the Simosato Hydrographic Observatory.

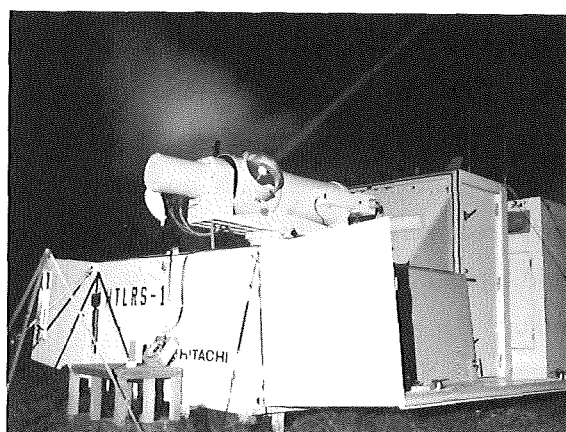

Figure 7. The transportable satellite laser ranging station, HTLRS-1.

extend ranging capability to high-orbiting satellites such as GPS. The recent range precision of the system is 4cm.

The transportable SLR system, HTLRS-1, transported to islands in order to make SLR observation there, was completed in October 1987 (Figure 7). The specifications and capa-

bilities of the systems are listed in Table 4 to meet the convenience of comparison. The range precision is about 5cm.

4.2 NNSS and GPS observations

The positions of the second order control points, relative to the first order or fiducial control points which are determined by SLR technique, have been determined using GPS or

Table 4. Comparison of specifications of the fixed-type and transportable SLR system in the JHD

	fixed-type (JHDLRS-1)	transportable (HTLRS-1)
aperture of receiving telescope	60 cm	35 cm
wave length of laser light	532 nm	532 nm
output energy of emitted laser pulse	125 mJ	50 mJ
width of laser pulse	100 ps	50 - 100 ps
repetition rate of laser shot	4 /sec	5 /sec
ranging precision per shot	4 cm	5 cm

NNSS differential techniques. Typical observation period for a site is 2 days for GPS and 3 days for NNSS. Brass or stone markers have been placed in the islands which identify the second order control points. Normally, NNSS or GPS receivers have been placed just above the control points. The islands, in which the second order control points are located, are usually small and sometimes have no ports or inhabitants. In these cases, survey vessels are used to land the islands. It is sometimes difficult to find out landing points when sea state is rough. It is often dangerous to go ashore with heavy receivers and batteries. We have to avoid typhoon season to improve possibility of landing.

Geodetic NNSS receivers (Magnavox MX 1502) were introduced to the JHD in 1980. The equipment consisted of the antenna with pre-amplifier and the receiver with data processor, data logger, precise oscillator and power supply. Built-in microprocessors usually controlled the whole system. It took a day to warm up oven for the oscillator. External batteries were used for field observations. Doppler observations to NNSS satellites were automatically recorded in cassette tapes in the receivers. Translocation strategy was applied to improve positioning accuracy of the second order control points. Two higher order control

points were used to determine the position of the second order control points. Typical precision of NNSS with translocation technique was 1-3meters for several hundred kilometers baselines.

In 1994, GPS took the place of NNSS in the observations for the marine geodetic control network. GPS, the successor of NNSS, provides real time navigation and has much better positioning accuracy both in point positioning and in relative positioning. At present, more than four GPS satellites are visible from anywhere at any time. GPS receivers for survey applications measure carrier phase of the GPS signal for L₁ and L₂ waves (1.2 and 1.5 GHz) as well as C/A and P code phase (1 and 10 MHz). Warm up process is not necessary for GPS receivers since precise clock is not required in GPS receivers. Dual frequency GPS receivers (TRIMBLE 4000SSi) have been used in the JHD. The weight of the GPS receiver, 3.1kg, is much lighter than that of NNSS thanks to technological innovations. The equipment consists of the antenna with preamplifier and the receiver with data processor, eighteen parallel channels, memory for data storage, oscillator and power supply. The receiver usually measures carrier phase every 30 seconds. The observed data are downloaded from the receiver to a personal computer after the observation. The carrier phase measurement enables precise relative positioning, 10⁻⁷ in accuracy, which is better than conventional survey techniques.

5. Analysis method

5.1 SLR

The development of an original orbital processor/analyzer to process the SLR data was started in 1980. Preliminary results of the sta-

tion coordinates including Simosato were first obtained in 1984 (Sasaki, 1984). The processor/analyzer was completed and named HYDRANGEA in 1988. By using HYDRANGEA, geocentric coordinates of SLR stations and geophysical quantities, such as earth rotation parameters and mass of the earth, have been estimated through the linear estimation theory (Sasaki, 1990).

The position of the Simosato Hydrographic Observatory in a global terrestrial reference frame has been determined by LAGEOS SLR data (Sasaki and Sengoku, 1993). SLR data to other geodetic satellites, such as Ajisai, have been also utilized (Sengoku, 1996).

In the HYDRANGEA analysis, LAGEOS data are divided into five-day arcs. Initial position and velocity of the satellite, geocentric coordinates of SLR stations and other geophysical parameters are estimated once in the five-day arc. Station coordinates of four foreign SLR stations are fixed to the station coordinate solution by the University of Texas at Austin (SSC (CSR) 86L07, Tapley et al., 1986). The movements of these fixed stations are known to be stable and close to the velocity predicted by the geological models such as NUVEL-1 (DeMets et al., 1990) and AM 0-2 (Minster and Jordan, 1978). The position of Simosato is determined every five days. Averaging process is effective in reducing scatter of the SLR station coordinates. Consequently, precise position of Simosato is estimated once a year.

Recently, plate tectonic theory is widely accepted. Plate tectonics assumes that the surface of the Earth is covered with several rigid plates that moves linearly and constantly on the Earth's surface. Plate tectonics was a revolutionary idea of geoscience which has changed

our understandings of seismic activity, mountain building, and volcanic activity. Plate tectonic theory suggests that the coordinates of the fiducial point is not stable but changing. Hence, we have to estimate the velocity of Simosato from yearly solution of the Simosato coordinates. The estimated movement of Simosato is discussed in section 6.

The positions of the HTLRS-1 have been also determined through analysis of SLR data by using HYDRANGEA. A special local analysis strategy, called SPORT (Sengoku, 1991), has been developed to improve the accuracy of the estimated baseline vectors. SPORT uses simultaneously observed data at Simosato and the first order control point in order to reduce the effect of orbit errors. The coordinates of Simosato are fixed to the values by the LAGEOS analysis.

Since 1997, a satellite data analysis software, GEODYN-II, has been used to determine the position of Simosato and the first order control points. The typical strategy of the recent SLR analysis procedure is to generate a few month arc using global SLR normal point data. Station positions are estimated once in the whole arc fixing the latitude of Greenbelt and the latitude and longitude of Maui. Some parameters, such as Earth rotation parameters and empirical accelerations, are estimated in shorter intervals. Accuracy and reliability have been significantly improved since then.

5.2 NNSS and GPS

The positions of the second order control points relative to the higher order control points are determined by using differential techniques of GPS or NNSS.

A commercial program, MAGNET, was used for NNSS analysis with translocation method. Translocation method was effective in remov-

ing errors commonly observed at nearby observation sites. MAGNET was operational at the mainframe computer at the JHD. Free network adjustment strategy was applied in MAGNET. The positions of second order control points were determined in the Tokyo Datum through re-adjustment of the network which was estimated by MAGNET to the Tokyo Datum.

In GPS analysis, GPSurvey software has been used. GPSurvey is a commercial software made by TRIMBLE Navigation Ltd. GPSurvey runs on a personal computer. Double difference or triple difference of carrier phases is used in the GPSurvey to reduce commonly observed errors, such as receiver/satellite clock errors and GPS orbit errors. Triple difference strategy is effective in finding cycle slips. We can remove ionospheric errors by using two frequency carrier phases. One baseline is determined in the GPSurvey analysis with precision of about 10^{-7} , 1cm for 100km, depending on the duration and quality of the observation. Recently, Bernese software, which has better accuracy for longer baselines, was installed in a work station in the JHD for the applications for geodynamics. It should be noted that the positioning accuracy has significantly improved by precise ephemerides of GPS satellites disseminated by International GPS Service for Geodynamics (IGS).

6. Results

6.1 Fiducial point, Simosato

The estimated position of the reference point of the SLR station at Simosato by our original software, HYDRANGEA, is shown in Table 5. The position of Simosato at the epoch 1990.0 can be estimated by fitting the coordinates with a linear function of time (Tatsuno and Fujita, 1994).

Table 5. Positioning results of the fiducial point at Simosato from SLR observations

epoch	U (m)	V (m)	W (m)
1984.80	-3822388.330	3699363.577	3507573.186
1985.99	.388	.577	.154
1986.76	.362	.594	.190
1988.11	.307	.540	.232
1989.95	.270	.562	.195
1990.97	.241	.615	.160

$$U = -3822388.272 \pm 0.019 \text{ (m)},$$

$$V = 3699363.582 \pm 0.017 \text{ (m)},$$

$$W = 3507573.187 \pm 0.018 \text{ (m)}.$$

Note that our terrestrial reference frame is very close to the widely accepted worldwide geodetic system ITRF, IERS Terrestrial Reference Frame determined by IERS. Typical difference between the systems is several cm. It is known that WGS-84, a terrestrial reference frame on which GPS is based, deviates from ITRF by several cm, transformation between the systems can be carried out through seven-parameter formula as follows,

$$\begin{pmatrix} u_2 \\ v_2 \\ w_2 \end{pmatrix} = \begin{pmatrix} u_1 \\ v_1 \\ w_1 \end{pmatrix} + \begin{pmatrix} \Delta u \\ \Delta v \\ \Delta w \end{pmatrix} + \begin{pmatrix} s & -r_w & r_v \\ r_w & s & -r_u \\ -r_v & r_u & s \end{pmatrix} \cdot \begin{pmatrix} u_1 \\ v_1 \\ w_1 \end{pmatrix}.$$

The reference point of SLR station at Simosato was connected to a nearby triangulation point by GPS. The difference in coordinates in two systems, the Tokyo Datum and the worldwide geodetic system, at Simosato stands for datum difference, primarily caused by origin difference. The method to connect two datums is discussed in section 7.

Plate boundary deformation at Simosato

Figure 8 shows the velocity estimate and its error ellipse for the Simosato SLR station relative to the Eurasian NUVEL-1 velocity determined by the JHD (Sengoku, 1998). The predicted motion of the Philippine sea plate at Simosato (Seno et al., 1993) is also shown in

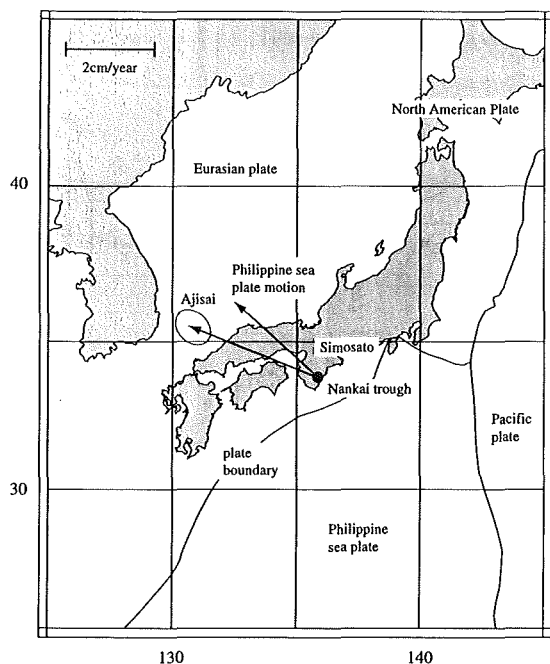

Figure 8. The velocity of the Simosato Hydrographic Observatory relative to the Eurasian plate motion determined from satellite laser ranging observation (Sengoku, 1998). The geological prediction of the Philippine sea plate motion (Seno et al., 1993) is also shown.

the figure. Simosato is moving southwestward relative to the subducting plate. Simosato is located at the subduction zone near the Nankai Trough where the Philippine sea plate subducts under the Eurasian plate. This location is known to have anomalous motion with respect to the Eurasian plate that might be caused by the collision of the plates (Sasaki, 1990, Smith et al., 1990). The distance from Simosato to the Nankai Trough is about 100km and the velocity of the subducting Philippine sea plate with respect to the Eurasian plate is about 3-4cm/year in this area. Hence, the discrepancy between the estimated and predicted velocities suggests the region be undergoing deformation in the plate boundary region. The amplitude of the estimated Simosato velocity is close to the subducting plate, which implies that the boundary between the Eurasian and the Philippine

sea plate is strongly coupled and both plates move together at the boundary.

6.2 First order and second order control points

Until 1996, the HTLRS-1 occupied 14 first order control points. Precise positions of the points were obtained by SLR analysis. The baseline lengths between Simosato and the first order control points range from 360km to 2000 km. Table 6 shows the estimated baseline vectors from Simosato to the first order control points (Fujita and Sengoku, 1997).

Distortion of the Tokyo Datum or errors in astronomically determined local datums, the difference between survey results from nearby triangulation points and SLR results in the Tokyo Datum, is shown in Figure 9. The difference between the Tokyo Datum and the worldwide geodetic system is also shown in the figure and Table 7. These values are determined by SLR observations at the first order control points. The positions of the off-lying islands on nautical charts have been corrected based on these results.

In 1996, the JHD started re-occupation of four first order control points by the HTLRS-1. The primary purpose is to determine rate of

Table 6. Estimated baseline vectors and baseline lengths from Simosato to the first order control points

site name	epoch	dx (m)	dy (m)	dz (m)	baseline length (m)
Titi Sima	1988.11	-668684.11	-217835.70	-620181.33	937665.03
Isigaki Sima	1988.62	556634.60	1110637.34	-893307.65	1530148.99
Minamitori Sima	1989.12	-1404801.74	-1147481.19	-899963.36	2024874.08
Okinawa	1989.58	317064.65	833377.42	-715320.02	1143123.20
Tusima	1989.82	477914.43	387712.73	56939.23	618033.53
Oki	1990.76	286183.85	50610.56	236845.19	374911.02
Minamidaito Sima	1991.13	36056.89	620952.63	-745609.07	970986.69
Tokai	1991.73	33930.50	-878445.59	764225.08	1164842.44
Iwo Sima	1992.13	-700413.43	-76723.17	-851341.16	1105100.53
Wakkanai	1992.73	299459.32	-920120.08	1010064.14	1398758.88
Hatizyo Sima	1993.14	-265491.96	-247599.34	-46670.81	366018.55
Makura Saki	1994.13	293938.66	463131.64	-216406.25	589680.01
Oga	1994.67	90895.74	-534958.25	570655.40	787457.90
Tyosi	1996.10	-198889.70	-425778.03	194093.25	508444.91

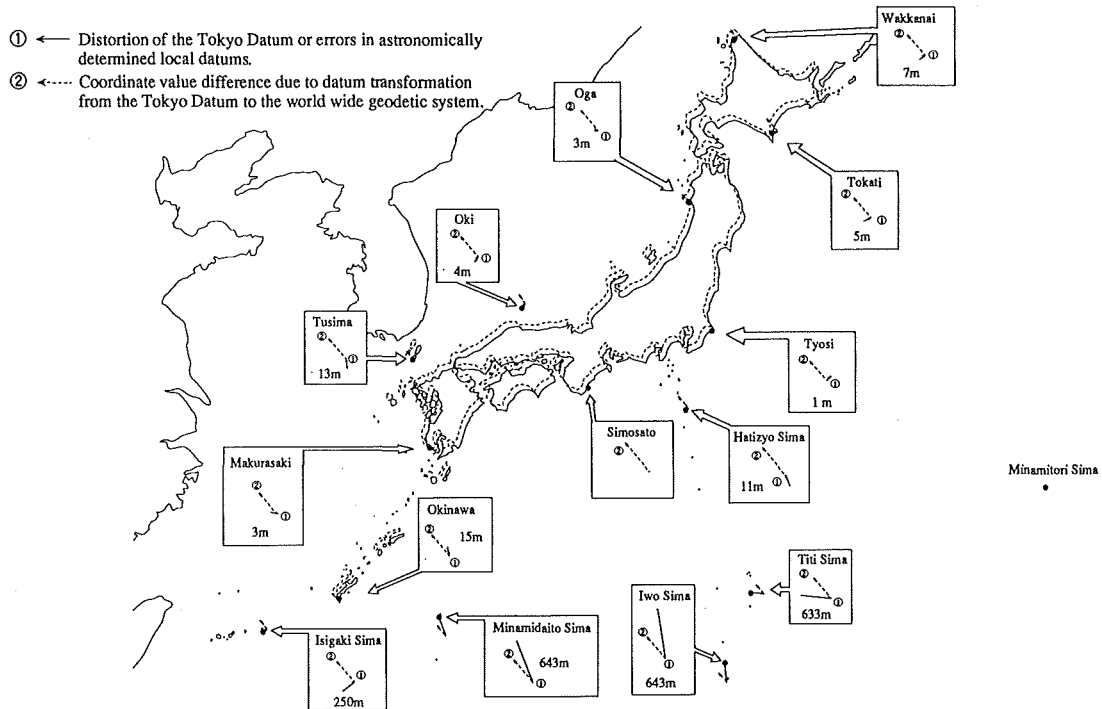

Figure 9. First order control points precisely determined by SLR. Distortion of the Tokyo Datum or errors in local datums, black arrows, was determined by comparing baseline vectors from Simosato to first order control points derived from SLR and ground survey results (detailed values are shown in Table 7). Coordinate value difference due to datum transformation from the Tokyo Datum to the worldwide geodetic system, dashed arrows, was determined by LAGEOS SLR results at Simosato.

Table 7. Distortion of the Tokyo Datum or errors in local datums at the first order control points

site	$\Delta\phi(^{\circ})$	$\Delta\lambda(^{\circ})$
Titi Sima	-3.891	22.584
Isigaki Sima	4.686	7.242
Okinawa	-0.416	0.310
Tusima	0.419	-0.079
Oki	0.095	0.100
Minamidaito Sima	-12.133	18.802
Tokati	0.028	0.218
Iwo Sima	-25.388	5.694
Wakkanai	0.141	0.256
Hatizyo Sima	0.347	-0.044
Makura Saki	-0.055	0.113
Oga	-0.043	0.110
Tyosi	-0.044	-0.028

change in coordinate. Most part of Japan is located at the plate boundary among the Eurasian, Philippine sea, North American, and Pacific plates (Figure 10). The observed movement of Titi Sima and Isigaki Sima with respect to the Eurasian plate are,

$$V_{titi} = 65\text{mm/year,}$$

$$Az_{titi} = 292\text{degree,}$$

$$V_{isi} = 37\text{mm/year,}$$

$$Az_{isi} = 175\text{degree,}$$

where V is the velocity and Az is the azimuth angle of the velocity vector (Fujita et al., 1998). The movement of Titi Sima is very close to the Philippine sea plate motion predicted by plate motion models, while that of Isigaki Sima significantly deviates from the prediction. Re-occupation of the HTLRS-1 will contribute to the understanding of large scale crustal deformation in Japan.

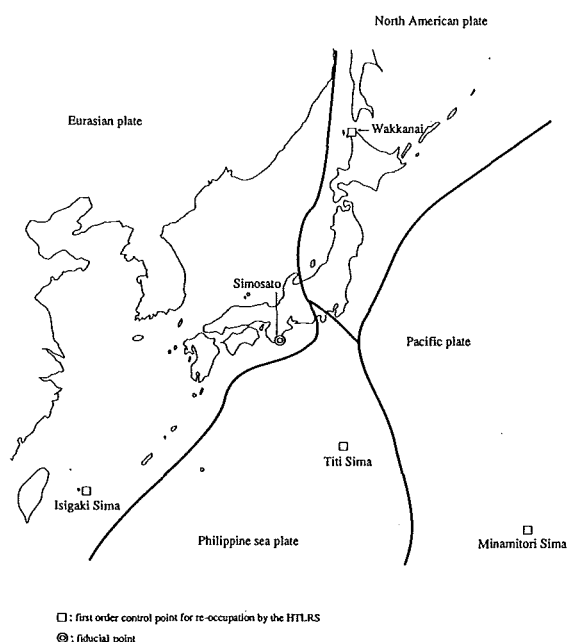

Figure 10. Re-occupation of the first order control points by the HTLRS-1.

The positions of the second order control points, except for three islands, were determined by GPS or NNSS until the end of 1998 (Terai and Fujita, 1996). The results have been utilized for determining baselines for the jurisdictional sea in the worldwide geodetic system.

7. Connection between the Tokyo Datum and the worldwide geodetic system

7.1 Method

General description

The geodetic coordinates of a point on the Earth's surface are represented in different values in two different geodetic systems due to the following causes.

1) Difference of the reference ellipsoid

When the reference ellipsoids in the systems are different, the coordinate values will differ. The reference ellipsoid is represented by the equatorial radius a and the flattening factor f . a and f of the Tokyo Datum and WGS-84 are as follows ;

$$a = 6377397.155 \text{ m}, f = 1/299.152813$$

(Tokyo Datum),

$$a = 6378137 \text{ m}, f = 1/298.257223563$$

(WGS-84).

2) Difference of the datum origin

When fitting the reference ellipsoid to the Earth's surface, coordinate values of a point of the ellipsoid, a datum origin, have to be defined. Historically, most of datum origins of national geodetic systems were defined independently from astronomical observations. Thus, significant inconsistencies do exist due to the deflection of the vertical at the origin or errors of the astronomical observations. As described in section 6, difference in datum scale or orientation affects the coordinate values. However, as far as the Tokyo Datum concerns, they have less effects in datum transformation, and are neglected in this report.

3) Distortion of the regional geodetic system

The regional geodetic systems have historically realized by conventional triangulation and have distortion due to observation errors and the deflection of the vertical, whereas global system is considered to be a uniform system. For individual charts, the transformation notes written on the charts should also contain the local distortion of the applied geodetic system. This value differs from one chart to another.

Mathematical description of datum transformation

Coordinate values of a geodetic system can be transformed into another system in the following way (Kanazawa, 1988).

1) Computation of rectangular coordinates

The rectangular coordinates of geodetic system 1, u , v , and w , are computed from geodetic coordinates, latitude ϕ , longitude λ , and height h .

$$u = (N + H) \cos \phi \cos \lambda,$$

$$\begin{aligned} v &= (N + H) \cos \phi \sin \lambda, \\ w &= \{N(1 - e^2) + H\} \sin \phi, \end{aligned} \quad (\text{A})$$

where

$$\begin{aligned} N &= a / \sqrt{1 - e^2 \sin^2 \phi}, \\ H &= h + h_g, \\ e^2 &= f(2 - f). \end{aligned}$$

H is the height from the reference ellipsoid. So it is the sum of the height above sea level h and the geoidal height h_g .

2) Origin shift

The rectangular coordinates of geodetic system 2, U , V and W , are easily computed as follows,

$$\begin{aligned} U &= u + \Delta u, \\ V &= v + \Delta v, \\ W &= w + \Delta w. \end{aligned}$$

3) Computation of geodetic coordinates

The geodetic coordinates in geodetic system 2 can be estimated by solving the equation described in 1). Generally, iterative computation is required to solve the non-linear equation (A) with sufficient accuracy.

7.2 Transformation parameters of geodetic systems

The position of Simosato was determined by LAGEOS SLR data from 1984 to 1990 in the worldwide geodetic system (Tatsuno and Fujita, 1994). The shift of the origin from the worldwide system to the Tokyo Datum can be determined by comparing the SLR result in the worldwide system and the ground survey result in the Tokyo Datum at Simosato as follows,

$$\begin{aligned} \Delta u &= 146.229(\text{m}), \\ \Delta v &= -507.565(\text{m}), \\ \Delta w &= -681.858(\text{m}). \end{aligned}$$

The geoidal height at Simosato is assumed to be zero (Ganeko, 1980). Note that origin shift be time-dependent and above values are for the epoch 1990.0. These values will be updated soon by state-of-the-art SLR analysis tech-

niques, using LAGEOS 1&2 SLR data in the 1990's, and coordinate value comparison at the Tokyo origin.

Distortion of the Tokyo Datum has been revealed by the first and second order control observations of the JHD (see SLR, NNSS and GPS observation reports in the Data Report of Hydrographic Observations). Repeated observation of the first order control points will be useful to understand distortion rate under way in the Japanese territory.

Implementation of the IHO Technical Resolution B.2.10

The Japan Hydrographic Department has published about 900 charts. About 500 charts out of them is over the scale of 1/500,000 which have transformation notes of geodetic system according to the IHO Technical Resolution B2.10.

The following table shows the transformation values of various regions of Japan derived from above origin shift value and the observed or interpolated distortion of the Tokyo Datum. They are mostly caused by difference in datum origin.

8. Future Prospects

In the last decade, many countries started adopting the world geodetic system as their national datums. For navigators, the world

Table 8. Transformation from WGS-84 to the Tokyo Datum

site	$\Delta\phi(^{\circ})$	$\Delta\lambda(^{\circ})$
Wakkanai	-0.121	0.234
Hakodate	-0.151	0.213
Siogama	-0.174	0.209
Yokohama	-0.191	0.191
Hirosima	-0.188	0.152
Kagosima	-0.206	0.136
Naha	-0.236	0.114

geodetic system is more convenient because they do not have to switch the datum when approaching to harbors. In this context, the Japanese national datum will be soon revised. A new datum based on the world geodetic system will take the place of the Tokyo Datum. All the nautical charts as well as land maps will be revised to meet the global trend and to enhance safety at sea. Our observation results will be utilized in the establishment of the new datum. Even if the Tokyo Datum is taken the place of by the datum, we need to continue our space geodetic activities. It is because the Earth is not rigid from the present geodesist's point of view. We need to re-observe the control points to detect crustal deformation. Our final goal is the maintenance of the distortion-free marine geodetic control network based on the world geodetic system with sophisticated accuracy and the contribution to the establishment of the world geodetic system which will benefit navigators for their positioning at sea.

Acknowledgments

The authors wish to thank the members of the Simosato Hydrographic Observatory and Geodesy and Geophysics Division of the Hydrographic Department of Japan.

references

- Degnan, J. J., Satellite Laser Ranging : Current Status and Future Prospects, *IEEE Transaction on Geoscience and Remote Sensing*, **GE-23**, No.4, 398, (1985).
- DeMets, C., R. G. Gordon, D. F. Argus, and S. Stein, Current plate motions, *Geophys. J. Int.*, **101**, 425, (1990).
- Fujita, M. and A. Sengoku, Estimation of Baseline Vectors between First Order Control Points and Simosato based on Analyses of AJISAI SLR Data, *Rep. of Hydrogr. Res.*, **33**, 1, (1997).
- Fujita, M., K. Terai, and A. Sengoku, Horizontal Motion of Chichijima Derived from Satellite Laser Ranging Observations, *Rep. of Hydrogr. Res.*, **34**, 13, (1997).
- Ganeko, Y., New Determination of a Marine Geoid around Japan, *Rep. of Hydrogr. Res.*, **15**, 71, (1980).
- Kanazawa, T., Transformation between WGS-84 and Tokyo Datum, *Data Report of Hydrogr. Obs., Series of Satellite Geodesy*, **1**, 77, (1988).
- Minster, J. B. and T. H. Jordan, Present-day plate motions, *J. Geophys. Res.*, **83**, 5331, (1978).
- Sasaki, M., Y. Ganeko, and Y. Harada, Satellite laser ranging system at Simosato Hydrographic Observatory, *Data Report of Hydrogr. Obs., Series of Astronomy and Geodesy*, **17**, 49, (1983).
- Sasaki, M., Satellite Laser Ranging at the Simosato Hydrographic Observatory and its Preliminary Results, *Journal of the Geod. Soc. Japan*, **30**, 29, (1984).
- Sasaki, M. and H. Hashimoto, Launch and Observation Program of the Experimental Geodetic Satellite of Japan, *IEEE Transactions on Geoscience and Remote Sensing*, **GE-25**, 526, (1987).
- Sasaki, M., Completion of a transportable SLR station of the Hydrographic Department, *Data Report of Hydrogr. Obs., Series of Satellite Geodesy*, **1**, 59, (1988).
- Sasaki, M., Study of the earth's dynamics by means of satellite laser ranging techniques, *Rep. of Hydrogr. Res.*, **26**, 99, (1990).
- Sasaki, M. and A. Sengoku, SLR observation and data analysis made by the Hydro-

- graphic Department of Japan in the last decade and the motion of the Simosato site, *Proc. of the International Workshop for Reference Frame Establishment and Technical Development in Space Geodesy (iRiS '93 TOKYO)*, p.134, Communications Research Lab., Tokyo, Jan. 18-21, (1993).
- Seeber, G., *Satellite Geodesy*, Walter de Gruyter, Berlin, Germany, p.22, (1993).
- Sengoku, A., Determination of the precise positions of Titi Sima and Isigaki Sima by Satellite Laser Ranging, *Rep. of Hydrogr. Res.*, **27**, 181, (1991).
- Sengoku, A., New surface force modelings on artificial satellites and their application to analysis of eight-year satellite laser ranging data of Ajisai, *doctoral dissertation*, the Graduate University of Advanced Studies, Tokyo, (1996).
- Sengoku, A., A plate motion study using Ajisai SLR data, *Earth Planets and Space*, **50**, 611, (1998).
- Seno, T., S. Stein, and A. E. Gripp, A Model for the Motion of the Philippine Sea Plate Consistent with NUVEL-1 and Geological Data, *J. Geophys. Res.*, **98**, 17941, (1993).
- Smith, D. E., R. Kolenkiewicz, P. J. Dunn, J. W. Robbins, M. H. Torrence, S. M. Klosko, R. G. Williamson, E. C. Pavlis, N. B. Douglas, and S. K. Fricke, Tectonic motion and deformation from satellite laser ranging to LAGEOS, *J. Geophys. Res.*, **95**, 22013, (1990).
- Tapley, B. D., R. J. Eanes and B. E. Schutz, Earth rotation from laser ranging to LAGEOS ; ERP (CS) 85L07, *Rep. MERIT-COTES Campaign on Earth Rotation and Reference Systems*, Part III, M. Feissel (ed.), IHB, Paris, B67, (1986).
- Tatsuno, T. and M. Fujita, Determination of the position of the mainland control point, *Data Report of Hydrogr. Obs., Series of Satellite Geodesy*, **7**, 102, (1994).
- Terai, K. and M. Fujita, Re-computation of positions of the second order control points in the marine geodetic control network, *Data Report of Hydrogr. Obs., Series of Satellite Geodesy*, **9**, 98, (1996).
- The observation and analysis reports of the space geodetic observations carried out by the Hydrographic Department of Japan were presented in the following Data Report series.
- SLR observations at Simosato*
- Sasaki, M. and M. Nagaoka, *Data Report of Hydrogr. Obs., Series of Astronomy and Geodesy*, **18**, 55, (1984).
- Sasaki, M., A. Sengoku, E. Nishimura and M. Nagaoka, *ibid.*, **19**, 50, (1985).
- Sasaki, M., A. Sengoku, M. Nagaoka and E. Nishimura, *ibid.*, **20**, 44, (1986).
- Kanazawa, T., A. Sengoku, M. Nagaoka, E. Nishimura, *ibid.*, **21**, 63, (1987).
- Kanazawa, T., A. Sengoku, M. Nagaoka, E. Nishimura, *Data Report of Hydrogr. Obs., Series of Satellite Geodesy*, **1**, 19, (1988).
- Kanazawa, T., A. Sengoku, M. Nagaoka, H. Nakagawa, *ibid.*, **2**, 1, (1989).
- Sengoku A., M. Nagaoka, K. Fuchida, S. Masai, T. Fujii and H. Nakagawa, *ibid.*, **3**, 1, (1990).
- Sengoku, A., S. Kurokawa and H. Nakagawa, *ibid.*, **4**, 1, (1991).
- Sengoku, A., S. Kurokawa, N. Ikeda and K. Matsumoto, *ibid.*, **5**, 1, (1992).
- Sengoku, A., S. Murakami, N. Ikeda and K. Matsumoto, *ibid.*, **6**, 1, (1993).
- Sengoku, A., Y. Narita and K. Matsumoto,

- ibid.*, 7, 1, (1994).
- Terai, K., M. Fujita, H. Matsushita and K. Muneda, *ibid.*, 8, 1, (1995).
- Terai, K., M. Fujita, H. Matsushita and K. Muneda, *ibid.*, 9, 1, (1996).
- Terai, K., H. Matsushita and K. Muneda, *ibid.*, 10, 1, (1997).
- Terai, K., M. Fujita, H. Matsushita, H. Watanabe and K. Muneda, *ibid.*, 11, 1, (1998).
- SLR observations at the first order control points*
- Fukushima, T., T. Uchiyama, E. Nishimura and A. Sengoku, *Data Report of Hydrogr. Obs., Series of Satellite Geodesy*, 4, 60, (1991). (in Japanese)
- Sengoku, A., T. Uchiyama and E. Nishimura, *ibid.*, 5, 43, (1992). (in Japanese)
- Sengoku, A., T. Uchiyama and E. Nishimura, *ibid.*, 6, 45, (1993). (in Japanese)
- Sengoku, A. and T. Uchiyama, *ibid.*, 7, 35, (1994). (in Japanese)
- Suzuki, A. and M. Fujita, *ibid.*, 8, 34, (1995). (in Japanese)
- Terai, K., M. Fujita, H. Matsushita and H. Watanabe, *ibid.*, 9, 30, (1996). (in Japanese)
- Matsumoto, K., H. Matsushita, S. Toyama, *ibid.*, 10, 42, (1997). (in Japanese)
- Terai, K., H. Noda and H. Matsushita, *ibid.*, 10, 52, (1997). (in Japanese)
- Terai, K., H. Fukura and H. Watanabe, *ibid.*, 11, 9, (1998). (in Japanese)
- NNSS observations*
- Takemura, T. and T. Kanazawa, *Data Report of Hydrogr. Obs., Series of Astronomy and Geodesy*, 17, 61, (1983). (in Japanese)
- Takemura, T., T. Kanazawa and M. Sawa, *ibid.*, 18, 42, (1984). (in Japanese)
- Takemura, T. and M. Sawa, *ibid.*, 19, 85, (1985). (in Japanese)
- Takemura, T. and K. Tomii, *ibid.*, 20, 72, (1986). (in Japanese)
- Takemura, T. and M. Nagaoka, *Data Report of Hydrogr. Obs., Series of Satellite Geodesy*, 1, 46, (1988). (in Japanese)
- Sengoku, A. and K. Asai, *ibid.*, 3, 77, (1990). (in Japanese)
- Kawai, K., K. Asai and S. Masai, *ibid.*, 5, 65, (1992). (in Japanese)
- Takanashi, Y., K. Kawai and N. Ikeda, *ibid.*, 6, 60, (1993). (in Japanese)
- Watanabe, Y., Y. Takanashi, K. Kawai and N. Ikeda, *ibid.*, 7, 49, (1994). (in Japanese)
- Watanabe, Y., A. Suzuki and Y. Narita, *ibid.*, 8, 46, (1995). (in Japanese)
- GPS observations*
- Matsumoto, K., Y. Sumiya and H. Matsushita, *Data Report of Hydrogr. Obs., Series of Satellite Geodesy*, 9, 44, (1988). (in Japanese)
- Watanabe, H., H. Noda, Y. Sumiya, H. Fukura and K. Masui, *ibid.*, 10, 59, (1997). (in Japanese)
- Terai, K., N. Ikeda and H. Fukura, *ibid.*, 11, 18, (1998). (in Japanese)

国内の島嶼等の精密位置決定

—海洋測地観測のレビュー—(要旨)

仙石 新, 藤田雅之, 松本邦雄,
寺井孝二, 佐々木 稔

海洋法条約によって管轄海域の境界線は海図上に記載されることとされ, また GPS による海上の精密な測位が可能となってきたことから, 正確な海図の重要性が増大している。このため, 水路部では, 1980年から人工衛星レーザー測距(SLR)や全世界測位システム(GPS)などの宇宙測地技術を用いて島嶼等の位置決定を行う海洋測地を推進している。本論文では, その概要をまとめる。